

# JF-800 双金属轴承规格及公差 JF-800 Bimetal Sleeve Bearing Specification & Tolerance

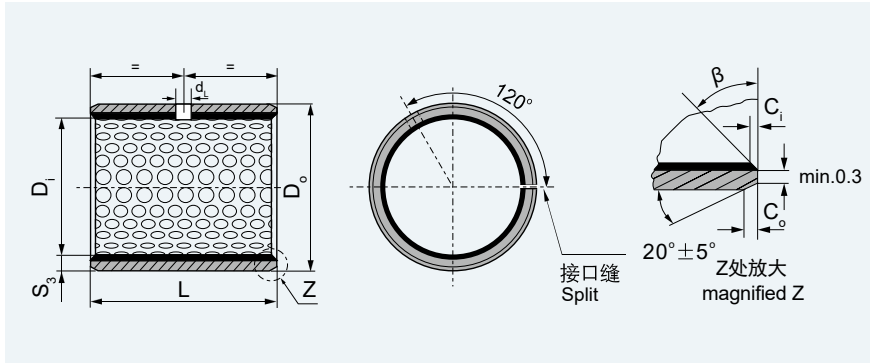

内外倒角 ID and OD chamfers

S <sub>3</sub>	C <sub>o</sub>	C <sub>i</sub>	β
0.75	0.5 ± 0.3	0.25 ± 0.2	35° ± 5°
1.00	0.6 ± 0.3	0.30 ± 0.2	35° ± 5°
1.50	0.7 ± 0.3	0.50 ± 0.3	35° ± 5°

S <sub>3</sub>	C <sub>o</sub>	C <sub>i</sub>	β
2.00	1.2 ± 0.4	0.50 ± 0.3	35° ± 5°
2.50	1.8 ± 0.6	0.60 ± 0.3	45° ± 5°

单位unit:mm<sup>2</sup>

内径 D <sub>i</sub> φ d	外径 D <sub>o</sub> φ D	轴径(h8) Shaft D <sub>s</sub>	座孔(H7) Housing D <sub>H</sub>	压装后 内孔公差 Arter fixed D <sub>ia</sub>	配合间隙 Clearance C <sub>D</sub>	壁厚 Wall thickness S <sub>3</sub>	油孔 Oil hole d <sub>l</sub>	长度 L <sub>0-40</sub>								
								10	15	20	25	30	40	50		
10	12	10	-0.022	12	+0.018	0.170 0.010		1010	1015	1020						
12	14	12	-0.027	14	+0.018			1210	1215	1220						
14	16	14	-0.027	16	+0.018	+0.148 +0.010		1410	1415	1420						
15	17	15	-0.027	17	+0.018		0.175 0.010	4	1510	1515	1520					
16	18	16	-0.027	18	+0.018				1610	1615	1620					
18	20	18	-0.027	20	+0.021	+0.151 +0.010	0.178 0.010		1810	1815	1820	1825				
20	23	20	-0.033	23	+0.021				2010	2015	2020	2025				
22	25	22	-0.033	25	+0.021	+0.161 +0.020	0.194 0.020	1.490 1.430	2210	2215	2220	2225				
24	27	24	-0.033	27	+0.021				2410	2415	2420	2425	2430			
25	28	25	-0.033	28	+0.021					2515	2520	2525	2530			
26	30	26	-0.033	30	+0.021	+0.181 +0.040	0.214 0.040			2615	2620	2625	2630			
28	32	28	-0.033	32	+0.025		0.218 0.040	6		2815	2820	2825	2830	2840		
30	34	30	-0.033	34	+0.025					3015	3020	3025	3030	3040		
32	36	32	-0.039	36	+0.025		1.980 1.920			3215	3220	3225	3230	3240		
35	39	35	-0.039	39	+0.025	+0.185 +0.040					3520	3525	3530	3540	3550	
38	42	38	-0.039	42	+0.025		0.224 0.040	8			3820	3825	3830	3840	3850	
40	44	40	-0.039	44	+0.025						4020	4025	4030	4040	4050	

# JF-800 双金属轴承规格及公差 JF-800 Bimetal Sleeve Bushing Specification & Tolerance

内径 D <sub>i</sub> φ d	外径 D <sub>o</sub> φ D	轴径(h8) Shaft D <sub>s</sub>	座孔(H7) Housing D <sub>H</sub>	压装后 内孔公差 Arter fixed D <sub>i,a</sub>	配合间隙 Clearance C <sub>D</sub>	壁厚 Wall thickness S <sub>3</sub>	油孔 Oil hole d <sub>L</sub>	长度 L <sup>0</sup> <sub>-0.40</sub>									
								25	30	40	50	60	80	90	100		
45	50	45 -0.039	50 +0.025	+0.225 +0.080	0.264 0.080			4525	4530	4540	4550						
50	55	50 -0.039	55 +0.030		0.269 0.080				5030	5040	5050	5060					
55	60	55 -0.046	60 +0.030						5530	5540	5550	5560					
60	65	60 -0.046	65 +0.030					8	6030	6040	6050	6060					
65	70	65 -0.046	70 +0.030	+0.230 +0.080	0.276 0.080				6530	6540	6550	6560					
70	75	70 -0.046	75 +0.030						7030	7040	7050	7060	7080				
75	80	75 -0.046	80 +0.030						7530	7540	7550	7560	7580				
80	85	80 -0.046	85 +0.035		0.281 0.080				8030	8040	8050	8060	8080	8090			
85	90	85 -0.054	90 +0.035						8530	8540	8550	8560	8580	8590	85100		
90	95	90 -0.054	95 +0.035							9040	9050	9060	9080	9090	90100		
95	100	95 -0.054	100 +0.035			2.460 2.400					9550	9560	9580	9590	95100		
100	105	100 -0.054	105 +0.035	+0.235 +0.080							10050	10060	10080	10090	100100		
105	110	105 -0.054	110 +0.035		0.289 0.080						10550	10560	10580	10590	105100		
110	115	110 -0.054	115 +0.035					9.5			11050	11060	11080	11090	110100		
115	120	115 -0.054	120 +0.035								11550	11560	11580	11590	115100		
120	125	120 -0.054	125 +0.040								12050	12060	12080	12090	120100		
125	130	125 -0.063	130 +0.040									12560	12580	12590	125100		
130	135	130 -0.063	135 +0.040									13060	13080	13090	130100		
135	140	135 -0.063	140 +0.040	+0.240 +0.080	0.303 0.080							13560	13580	13590	135100		
140	145	140 -0.063	145 +0.040									14060	14080	14090	140100		
150	155	150 -0.063	155 +0.040									15060	15080	15090	150100		